

**13266****VOLVO V-70 AND XC-70 (PAGE 1 OF 2)**

6/18/2008

GROSS LOAD CAPACITY WHEN USED AS A WEIGHT CARRYING HITCH: 3,500 LBS. TRAILER WEIGHT & 350 LBS. TONGUE WEIGHT.  
**\*\*\*DO NOT EXCEED VEHICLE MANUFACTURER'S RECOMMENDED TOWING CAPACITY.\*\*\***

**TOOLS REQUIRED**

T-20 TORX DRIVER
8, 10, 13 AND 17mm SOCKETS
6" EXTENSION
RATCHET
TORQUE WRENCH
DREMEL TOOL

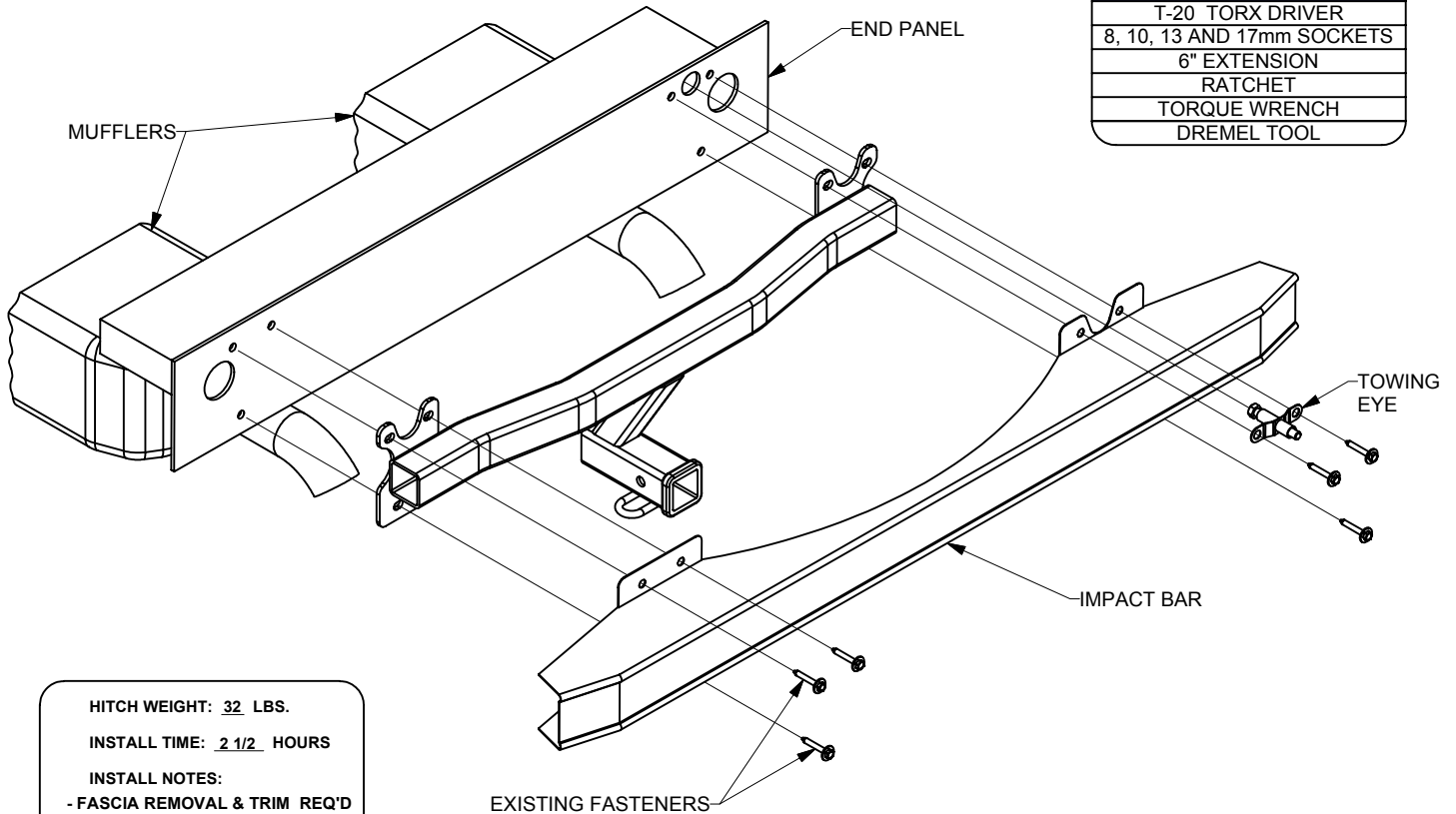
HITCH WEIGHT: 32 LBS.INSTALL TIME: 2 1/2 HOURS**INSTALL NOTES:**

- FASCIA REMOVAL & TRIM REQ'D
- NO DRILL REQ'D

**INSTALLATION STEPS**

- NOTIFY VEHICLE OWNER THAT FASCIA REQUIRES TRIMMING TO FIT HITCH.
  - RECOMMEND TWO PERSONS TO REMOVE THE FASCIA TO PREVENT SCRATCHES OR DAMAGE.
1. Remove rear bumper fascia. Disconnect back-up sensor wiring if present. (Not shown)
    - a. Remove (2) plastic fasteners from the rear of the vehicle. (See Figure 1)
    - b. Open hatch. Remove two rubber hatch stops. (See Figure 2)
    - c. Remove 4 screws (each side) from the plastic wheel well molding. (See Figure 3)
    - d. Gently pull the plastic fascia away from the wheel well molding. (See Figure 4)
    - e. Gently continue to remove the fascia. At the tail light pull gently rearward.
    - f. Pull gently on the fascia until the rear fascia is completely removed from the vehicle.
  2. Loosen the towing eye.
    - a. Remove the (2) bolts retaining the inside appearance panel at the rear of the hatch.
    - b. Loosen the towing eye under the appearance panel, rear passenger side (1 bolt). (See Figure 5)
  3. Remove impact bar. (Continue to loosen the towing eye as needed to remove the impact bar.)
  4. Place hitch into impact bar aligning holes.
  5. Raise hitch and impact bar into position. Re-install the existing fasteners. Hand tighten driver side and lower passenger side bolts.
  6. Re-install towing eye (sandwich hitch, impact bar and towing eye). Hand tighten bolts (6).
  7. Tighten all M10 fasteners to 39 lb-ft.
  8. Re-tighten towing eye hook from inside vehicle.
  9. Replace the (2) bolts that retain the inside appearance panel at rear of tailgate
  10. Using a Dremel tool, carefully cut out the fascia on the bottom inside fascia. Locate the bottom center of the fascia and trim as shown. See Figure 1 for trim dimensions. Note: Area marked on fascia is trim outline for factory Volvo hitch.
  11. Re-install fascia. Note: Make sure fascia sits flat along rear shelf of trunk.

**PERIODICALLY CHECK THIS RECEIVER HITCH TO ENSURE THAT ALL FASTENERS ARE TIGHT AND THAT ALL STRUCTURAL COMPONENTS ARE SOUND.**

Curt Manufacturing Inc., warrants this product to be free of defects in material and/or workmanship at the time of retail purchase by the original purchaser. If the product is found to be defective, Curt Manufacturing Inc., may repair or replace the product, at their option, when the product is returned, prepaid, with proof of purchase. Alteration to, misuse of, or improper installation of this product voids the warranty. Curt Manufacturing Inc.'s liability is limited to repair or replacement of products found to be defective, and specifically excludes liability for incidental or consequential loss or damage.

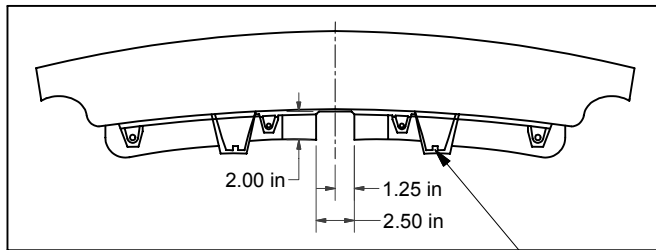
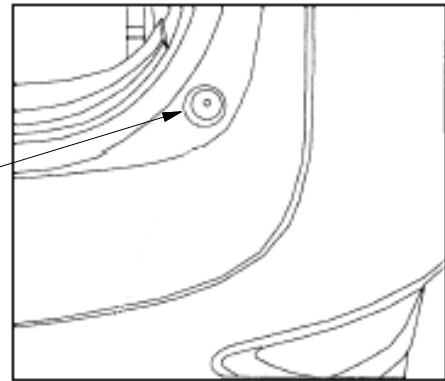
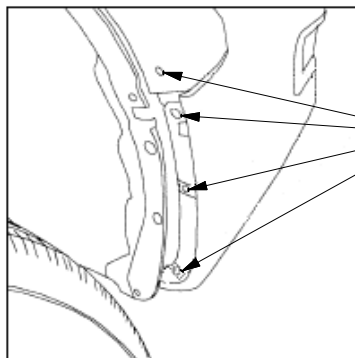

FIGURE 1  
(AS VIEWED FROM BOTTOM) PLASTIC FASTENERS



RUBBER HATCH STOP

FIGURE 2



REMOVE (4) SCREWS (EACH SIDE)  
FROM PLASTIC WHEEL WELL MOLDING

FIGURE 3

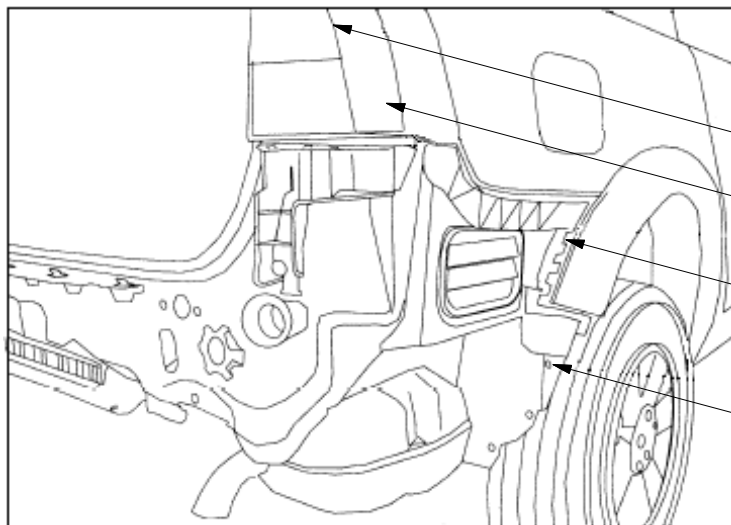

TAIL LIGHT

PULL FASCIA REARWARD  
GENTLY AT THE TAIL LIGHT

GENTLY PULL THE FASCIA AWAY  
FROM THE WHEEL WELL MOLDING

REMOVE (4) SCREWS (EACH SIDE)  
FROM THE PLASTIC WHEEL WELL MOLDING

FIGURE 4

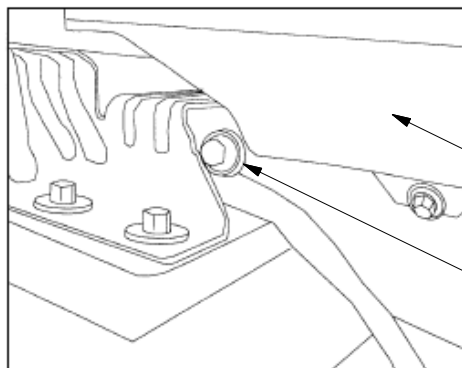

REMOVE INNER  
APPEARANCE PANEL

LOOSEN TOWING EYE UNDER REAR  
PASSENGER SIDE APPEARANCE PANEL

FIGURE 5