

11513

2004-2005 BMW 645ci

6/3/2009

PAGE 1 OF 2

GROSS LOAD CAPACITY WHEN USED AS A WEIGHT CARRYING HITCH: 2,000 LBS. TRAILER WEIGHT & 200 LBS. TONGUE WEIGHT.

DO NOT EXCEED VEHICLE MANUFACTURER'S RECOMMENDED TOWING CAPACITY.

WARNING: ALL NON-TRAILER LOADS APPLIED TO THIS PRODUCT MUST BE SUPPORTED BY AUXILIARY STABILIZING STRAPS.

** FAILURE TO PROPERLY SUPPORT NON-TRAILER LOADS WILL VOID PRODUCT WARRANTY**

HAVING INSTALLATION QUESTIONS? CALL TECHNICAL SUPPORT AT 1-800-798-0813

Parts List			
ITEM	QTY	PART NUMBER	DESCRIPTION
1	4	M10 - 1.5 x 30 HEX	HEX BOLT
2	5	3/8"	CONICAL TOOTHED WASHER
3	2	7/16-14 x 1	CARRIAGE BOLT
4	2	7/16-14	HEX FLANGE NUT
5	1	M10 - 1.5 x 35mm	HEX TAP BOLT

FRONT
↑
REAR

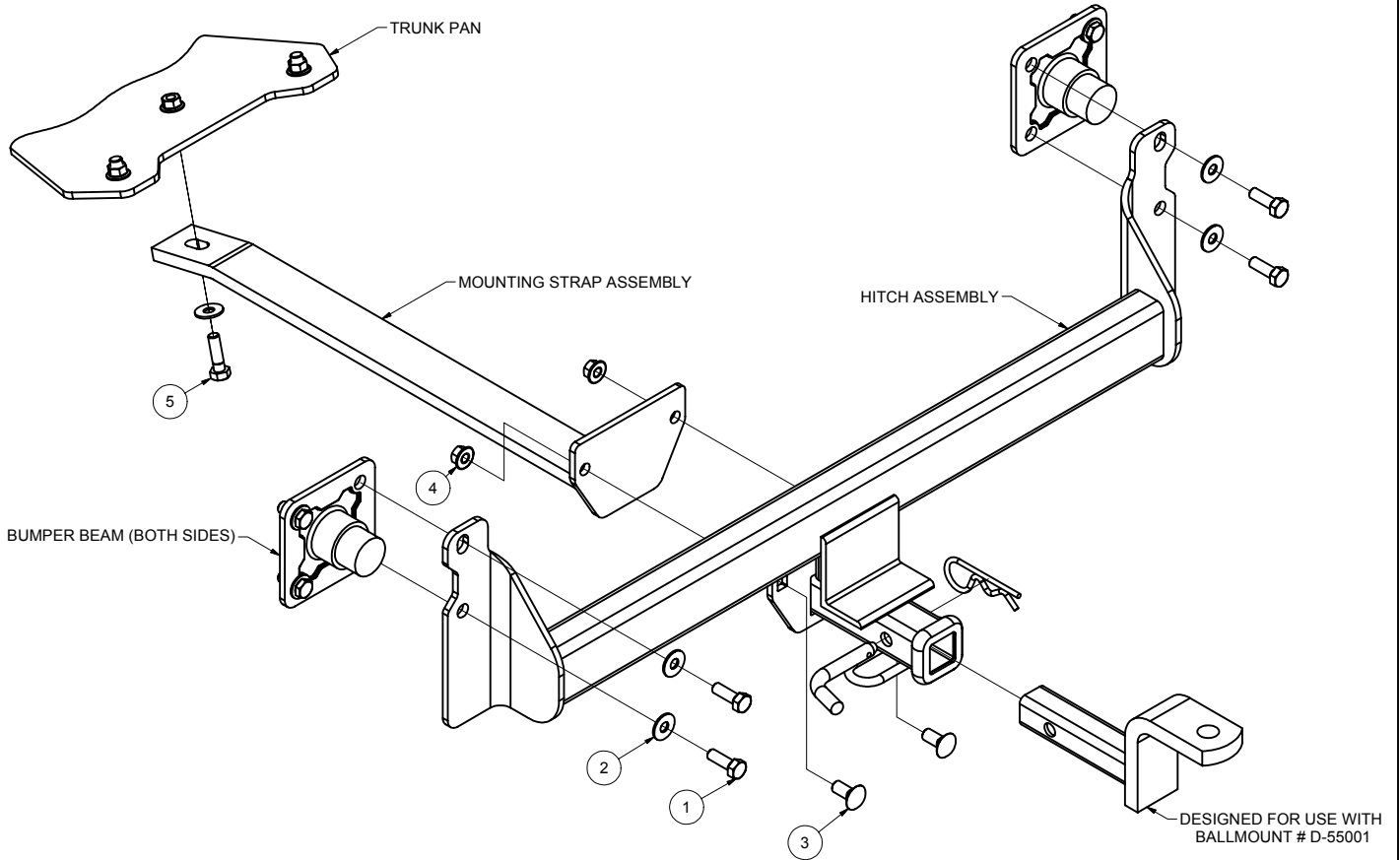

HITCH WEIGHT: 34 LBS.

INSTALL TIME

PROFESSIONAL: 20 MINUTES

NOVICE (DIY): 45 MINUTES

INSTALL NOTES:

- NO DRILLING REQUIRED
- REMOVE UNDERBODY PANEL
- REMOVE FACTORY HARDWARE

WELDNUT CLEANING

To remove debris from weldnuts in frame, spray lubricant or compressed air into hole. For heavy debris, use a small wire brush. (Be careful not to damage threads).

PERIODICALLY CHECK THIS RECEIVER HITCH TO ENSURE THAT ALL FASTENERS ARE TIGHT AND THAT ALL STRUCTURAL COMPONENTS ARE SOUND.

Curt Manufacturing Inc., warrants this product to be free of defects in material and/or workmanship at the time of retail purchase by the original purchaser. If the product is found to be defective, Curt Manufacturing Inc., may repair or replace the product, at their option, when the product is returned, prepaid, with proof of purchase. Alteration to, misuse of, or improper installation of this product voids the warranty. Curt Manufacturing Inc.'s liability is limited to repair or replacement of products found to be defective, and specifically excludes liability for incidental or consequential loss or damage.

GROSS LOAD CAPACITY WHEN USED AS A WEIGHT CARRYING HITCH: 2,000 LBS. TRAILER WEIGHT & 200 LBS. TONGUE WEIGHT.

*****DO NOT EXCEED VEHICLE MANUFACTURER'S RECOMMENDED TOWING CAPACITY.*****

WARNING: ALL NON-TRAILER LOADS APPLIED TO THIS PRODUCT MUST BE SUPPORTED BY AUXILIARY STABILIZING STRAPS.

**** FAILURE TO PROPERLY SUPPORT NON-TRAILER LOADS WILL VOID PRODUCT WARRANTY****

HAVING INSTALLATION QUESTIONS? CALL TECHNICAL SUPPORT AT 1-800-798-0813

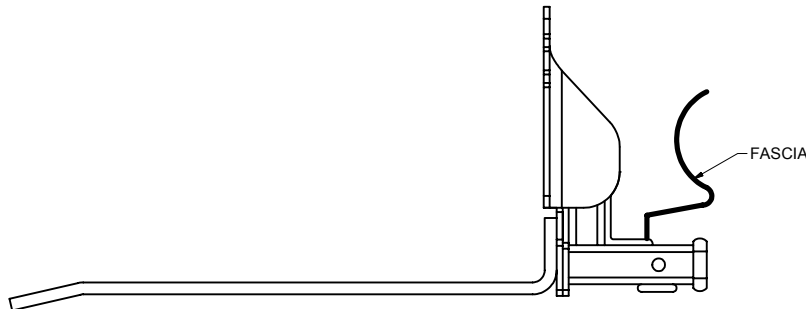

INSTALLED HITCH POSITION

TOOLS REQUIRED
SOCKET WRENCH
TORQUE WRENCH
16mm SOCKET / WRENCH
17mm SOCKET / WRENCH
11/16" SOCKET / WRENCH
10mm SOCKET
10" SOCKET EXTENSION
UNIVERSAL JOINT ADAPTER
SMALL FLAT SCREWDRIVER



REMOVE BOLTS
(2 PER SIDE)

BUMPER BEAM BOLT REMOVAL DIAGRAM
(DRIVER SIDE SHOWN)

INSTALLATION STEPS

- Using a small flat screwdriver, unclip the center underbody panel from the rear bumper fascia.
- Pull rear of center underbody panel down enough to allow access to nuts holding panel to vehicle trunk pan.
- Using a 10" socket extension, universal joint adapter, and 10mm socket, remove three (3) factory nuts holding center underbody panel to the vehicle trunk pan.
- Remove center underbody panel. Return panel and nuts to vehicle owner.
- Remove two (2) bolts from inside of bumper beam on both driver and passenger side of vehicle. Return bolts to vehicle owner. (See BUMPER BEAM BOLT REMOVAL DIAGRAM.)
- Remove one (1) bolt from center of trunk pan. Return bolt to vehicle owner.
- Raise HITCH ASSEMBLY into position. Install supplied M10-1.50 x 30mm bolts and 3/8 in. conical toothed washers through HITCH ASSEMBLY, as shown.
- Secure MOUNTING STRAP ASSEMBLY to HITCH ASSEMBLY with 7/16 in. carriage bolts and hex flange nuts, as shown.
- Secure MOUNTING STRAP ASSEMBLY to trunk pan with M10-1.50 x 35mm bolt and 3/8 in. conical toothed washer, as shown.
- Torque M10-1.50 hardware to 35 lb-ft and 7/16 in. hardware to 50 lb-ft.

PERIODICALLY CHECK THIS RECEIVER HITCH TO ENSURE THAT ALL FASTENERS ARE TIGHT AND THAT ALL STRUCTURAL COMPONENTS ARE SOUND.