

11415

**SAAB 9-3 SPORT COMBI WAGON
(ALL EXCEPT DUAL EXHAUST MODELS)**

5/27/2009

**GROSS LOAD CAPACITY WHEN USED AS A WEIGHT CARRYING HITCH: 2000 LBS. TRAILER WEIGHT & 200 LBS. TONGUE WEIGHT.
DO NOT EXCEED VEHICLE MANUFACTURER'S RECOMMENDED TOWING CAPACITY.**

Parts List			
ITEM	QTY	PART NUMBER	DESCRIPTION
1	1	3/8-16 x 1 1/4 LG.	CARRIAGE BOLT
2	1	HFN3816	HEX FLANGE NUT
3	2	CM-SP7	.250 x 1.00 x 2.00" SQUARE HOLE SPACER
4	1	CM-SP48	.250 x 2.13 x 2.13" SQUARE HOLE SPACER
5	1	CM-SP18	.250 x 1.00 x 2.00" SQUARE HOLE SPACER
6	2	7/16-14 x 1 1/2	CARRIAGE BOLT
7	1	1/2-13 x 2"	HEX BOLT
8	2	7/16-14	HEX FLANGE NUT
9	1	HFN 1213	HEX FLANGE NUT
10	1	CM-438-FW	7/16" FISHWIRE TOOL

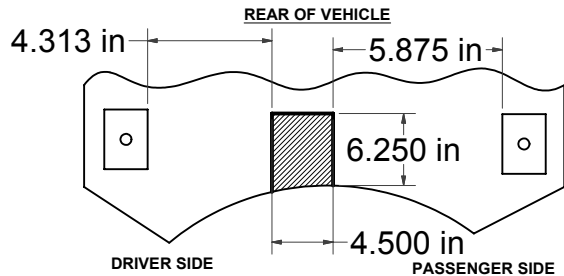

PLASTIC UNDER BODY PANEL CUTOUT DIAGRAM

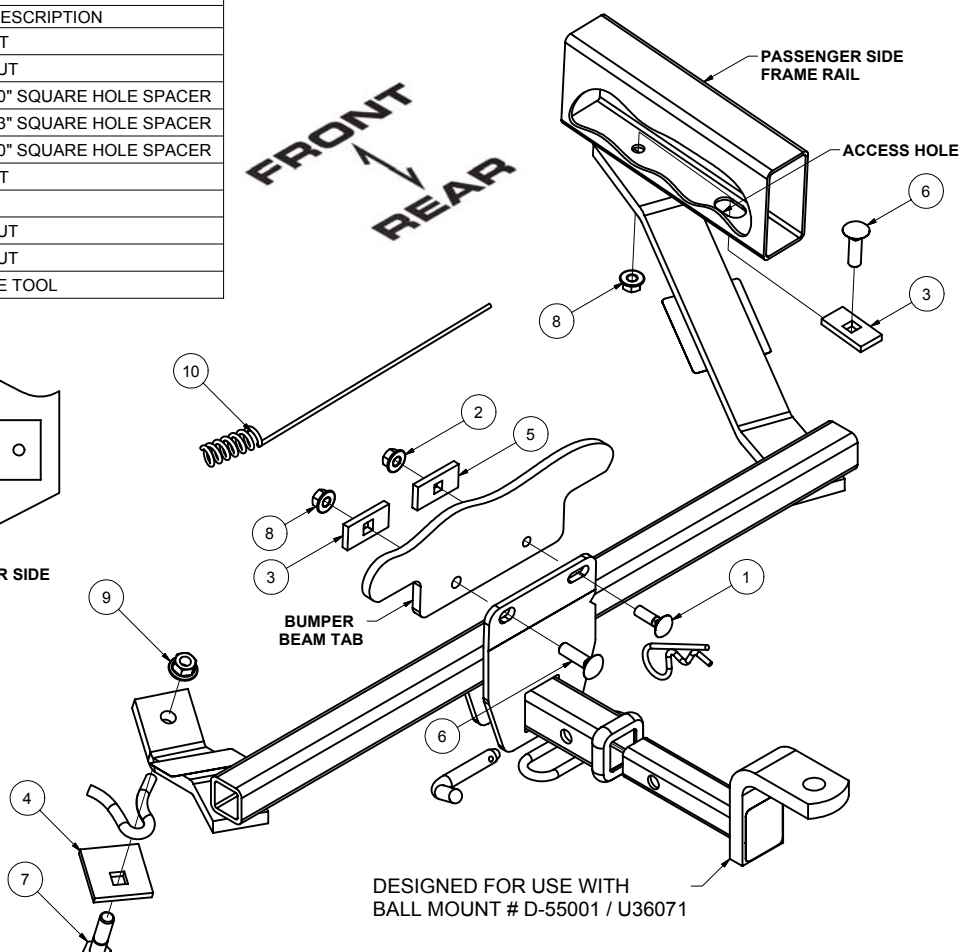
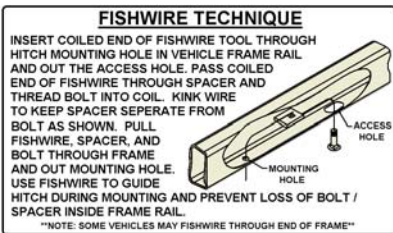

DESIGNED FOR USE WITH BALL MOUNT # D-55001 / U36071

HITCH WEIGHT: 26 LBS.

INSTALL TIME

PROFESSIONAL: 60 MINUTES
 NOVICE (DIY): 125 MINUTES

INSTALL NOTES:

- NO DRILLING REQUIRED
- LOWER AND TRIM FASCIA

TOOLS REQUIRED
10mm, 3/8", 7/16", 1/2" SOCKETS
RATCHET
TORQUE WRENCH

INSTALLATION STEPS

- 1) Remove (2) fascia nuts from the under body panel and lower panel from vehicle. (Nuts will be reinstalled in step 8)
- 2) Trim under body panel as shown in plastic under body panel cutout diagram.
- 3) Fishwire 7/16" carriage bolt and spacer in through the access hole and out the mounting hole in the passenger side frame rail. Leave fishwire attached. (See fishwire technique diagram)
- 4) Raise hitch into position over fishwired bolt, remove fishwire and secure with flange nut.
- 5) Use 3/8" and 7/16" carriage bolts, spacers and flange nuts to secure the center of the hitch to the bumper beam tab as shown.
- 6) Secure driver side arm to top of tow loop using 1/2" bolt, spacer, and flange nut as shown.
- 7) Torque all 1/2" fasteners to 75 lb-ft, all 7/16" fasteners to 50 lb-ft, and all 3/8" fasteners to 30 lb-ft.
- 8) Reinstall the fascia nuts. (Nuts that were removed in step 1)

PERIODICALLY CHECK THIS RECEIVER HITCH TO ENSURE THAT ALL FASTENERS ARE TIGHT AND THAT ALL STRUCTURAL COMPONENTS ARE SOUND.

Curt Manufacturing Inc., warrants this product to be free of defects in material and/or workmanship at the time of retail purchase by the original purchaser. If the product is found to be defective, Curt Manufacturing Inc., may repair or replace the product, at their option, when the product is returned, prepaid, with proof of purchase. Alteration to, misuse of, or improper installation of this product voids the warranty. Curt Manufacturing Inc.'s liability is limited to repair or replacement of products found to be defective, and specifically excludes liability for incidental or consequential loss or damage.