

GROSS LOAD CAPACITY WHEN USED AS A WEIGHT CARRYING HITCH: 2,000 LBS. TRAILER WEIGHT & 200 LBS. TONGUE WEIGHT.

*****DO NOT EXCEED VEHICLE MANUFACTURER'S RECOMMENDED TOWING CAPACITY.*****

WARNING: ALL NON-TRAILER LOADS APPLIED TO THIS PRODUCT MUST BE SUPPORTED BY AUXILIARY STABILIZING STRAPS.

**** FAILURE TO PROPERLY SUPPORT NON-TRAILER LOADS WILL VOID PRODUCT WARRANTY****

HAVING INSTALLATION QUESTIONS? CALL TECHNICAL SUPPORT AT 1-800-798-0813

Parts List			
ITEM	QTY	PART NUMBER	DESCRIPTION
1	4	3/8"	CONICAL TOOTHED WASHER
2	2	7_16 FISHWIRE	7/16" FISHWIRE
3	2	7/16-14 x 1 1/2	CARRIAGE BOLT
4	2	CM-SP7	.250 x 1.00 x 2.00" SQUARE HOLE SPACER
5	2	7/16-14	HEX FLANGE NUT
6	1	M10-1.25 x 35	HEX BOLT
7	3	M10 - 1.25 HEX-NUT	Hex Nut

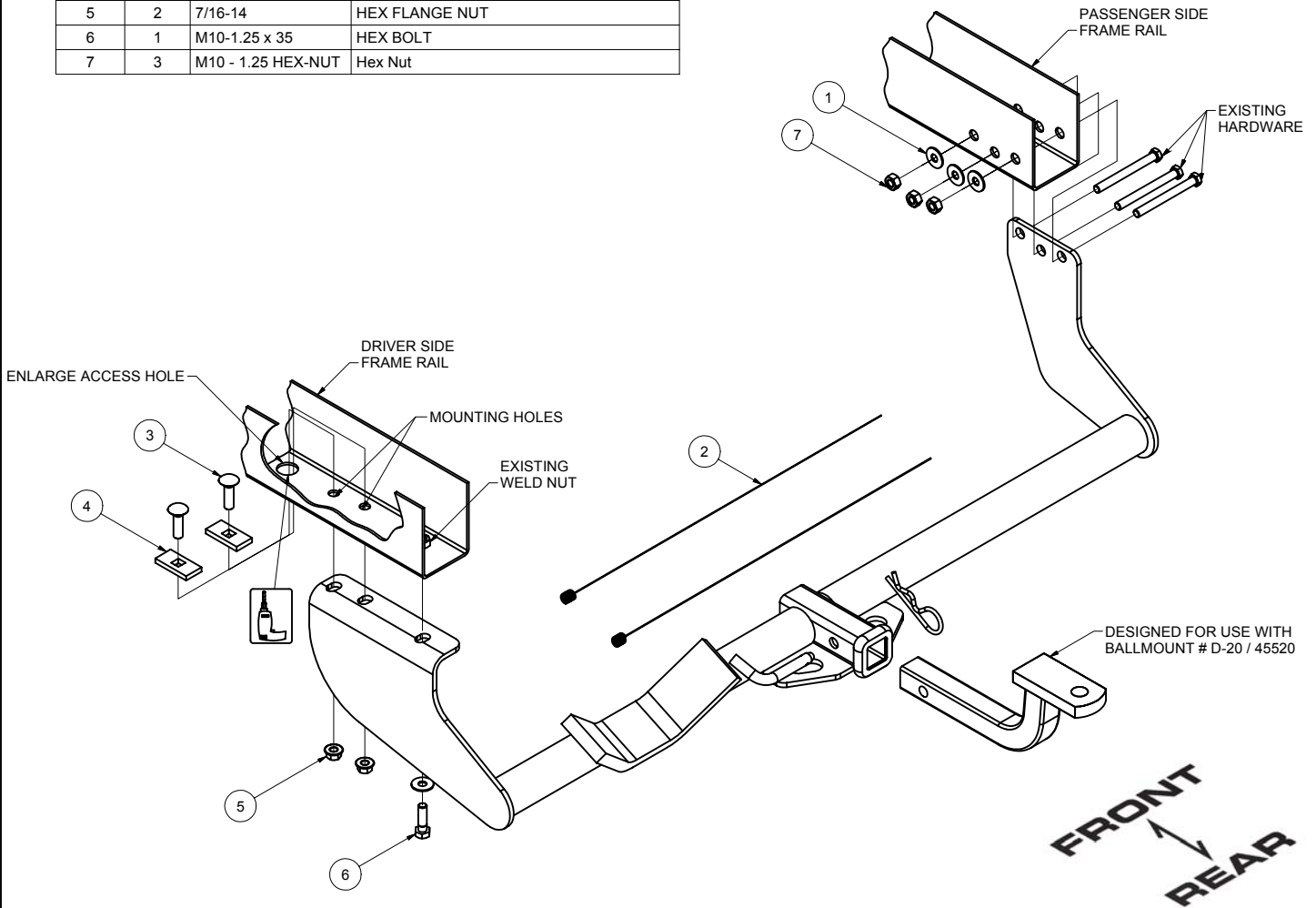

HITCH WEIGHT: .35 LBS.

INSTALL TIME

PROFESSIONAL: 30 MINUTES

NOVICE (DIY): 60 MINUTES

INSTALL NOTES:

- REMOVE EXISTING HARDWARE
- FISHWIRE HARDWARE
- HOLE ENLARGEMENT
- LOWER EXHAUST

TOOLS REQUIRED

RATCHET
10" EXTENTION
ROTARY TOOL
TORQUE WRENCH
16MM WRENCH
16MM SOCKET
17MM SOCKET
7/16" SOCKET

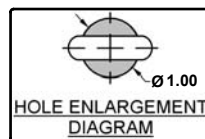

PERIODICALLY CHECK THIS RECEIVER HITCH TO ENSURE THAT ALL FASTENERS ARE TIGHT AND THAT ALL STRUCTURAL COMPONENTS ARE SOUND.

Curt Manufacturing Inc., warrants this product to be free of defects in material and/or workmanship at the time of retail purchase by the original purchaser. If the product is found to be defective, Curt Manufacturing Inc., may repair or replace the product, at their option, when the product is returned, prepaid, with proof of purchase. Alteration to, misuse of, or improper installation of this product voids the warranty. Curt Manufacturing Inc.'s liability is limited to repair or replacement of products found to be defective, and specifically excludes liability for incidental or consequential loss or damage.

GROSS LOAD CAPACITY WHEN USED AS A WEIGHT CARRYING HITCH: 2,000 LBS. TRAILER WEIGHT & 200 LBS. TONGUE WEIGHT.

*****DO NOT EXCEED VEHICLE MANUFACTURER'S RECOMMENDED TOWING CAPACITY.*****

WARNING: ALL NON-TRAILER LOADS APPLIED TO THIS PRODUCT MUST BE SUPPORTED BY AUXILIARY STABILIZING STRAPS.

**** FAILURE TO PROPERLY SUPPORT NON-TRAILER LOADS WILL VOID PRODUCT WARRANTY****

HAVING INSTALLATION QUESTIONS? CALL TECHNICAL SUPPORT AT 1-800-798-0813

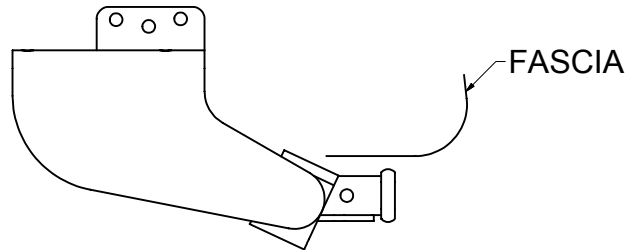

INSTALLED HITCH POSITION

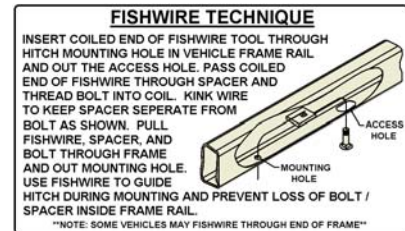
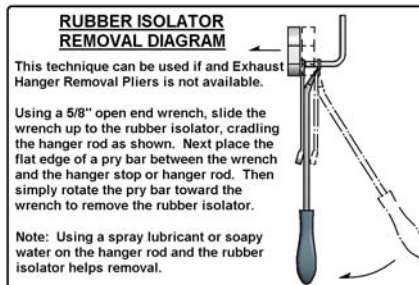
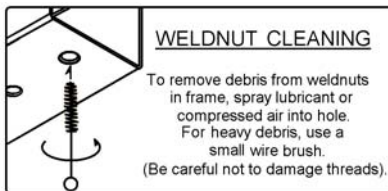

INSTALLATION STEPS

1. Using a 16mm wrench, remove the three factory bolts and the factory tow hook on the passenger side of vehicle. Return tow hook to the vehicle owner and save factory hardware to be used in step 6.
2. Enlarge access hole on the drivers side frame rail enough to allow the CM-SP7 spacer to pass through, as shown. (See hole enlargement diagram)
3. Fishwire 7/16"-14 x 1 1/2" bolts and CM-SP7 spacers through mounting holes, as shown. (See fishwire technique diagram)
4. Remove the rear most rubber isolator from the top exhaust hanger. (Refer to rubber isolator removal diagram)
5. Raise hitch into position.
6. Reinstall the existing hardware from step (1) through the passenger side plate and frame rail. Install 3/8" conical toothed washers and M10-1.25 hex nuts onto bolts.
7. Install M10-1.25 hex bolt and 3/8" conical toothed washer through the existing weld nut on drivers side frame rail.
8. Install 7/16" hex flange nuts onto carriage bolts from step 3.
9. Reinstall the rubber isolator onto the new exhaust hanger located on the driver side plate of hitch.
10. Torque all 7/16" fasteners to 50 lb-ft. Torque all 10mm fasteners to 35 lb-ft.

PERIODICALLY CHECK THIS RECEIVER HITCH TO ENSURE THAT ALL FASTENERS ARE TIGHT AND THAT ALL STRUCTURAL COMPONENTS ARE SOUND.