

GROSS LOAD CAPACITY WHEN USED AS A WEIGHT CARRYING HITCH: 2,000 LBS. TRAILER WEIGHT & 200 LBS. TONGUE WEIGHT.

*****DO NOT EXCEED VEHICLE MANUFACTURER'S RECOMMENDED TOWING CAPACITY.*****

WARNING: ALL NON-TRAILER LOADS APPLIED TO THIS PRODUCT MUST BE SUPPORTED BY AUXILIARY STABILIZING STRAPS.

**** FAILURE TO PROPERLY SUPPORT NON-TRAILER LOADS WILL VOID PRODUCT WARRANTY****

HAVING INSTALLATION QUESTIONS? CALL TECHNICAL SUPPORT AT 1-800-798-0813

| Parts List | | | |
|------------|-----|---------------------|--|
| ITEM | QTY | PART NUMBER | DESCRIPTION |
| 1 | 2 | 1_2 FISHWIRE | 1/2" FISHWIRE |
| 2 | 4 | HFN 1213 | HEX FLANGE NUT |
| 3 | 4 | CM-SP6 | .250 x 1.00 x 3.00" SQUARE HOLE SPACER |
| 4 | 4 | 1/2-13 x 1 1/2 | CARRIAGE BOLT |
| 5 | 2 | 7/16 | WASHER |
| 6 | 2 | M10 - 1.5 x 110 HEX | HEX BOLT |
| 7 | 2 | 7/16" | CONICAL TOOTHED WASHER |
| 8 | 2 | M10 - 1.50 HEX-NUT | Hex Nut |

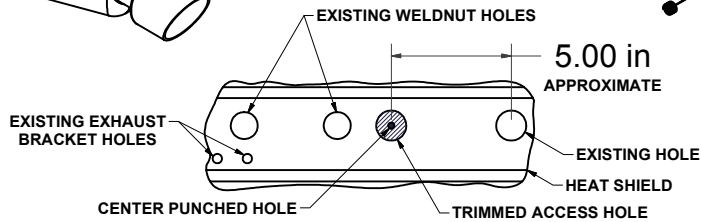
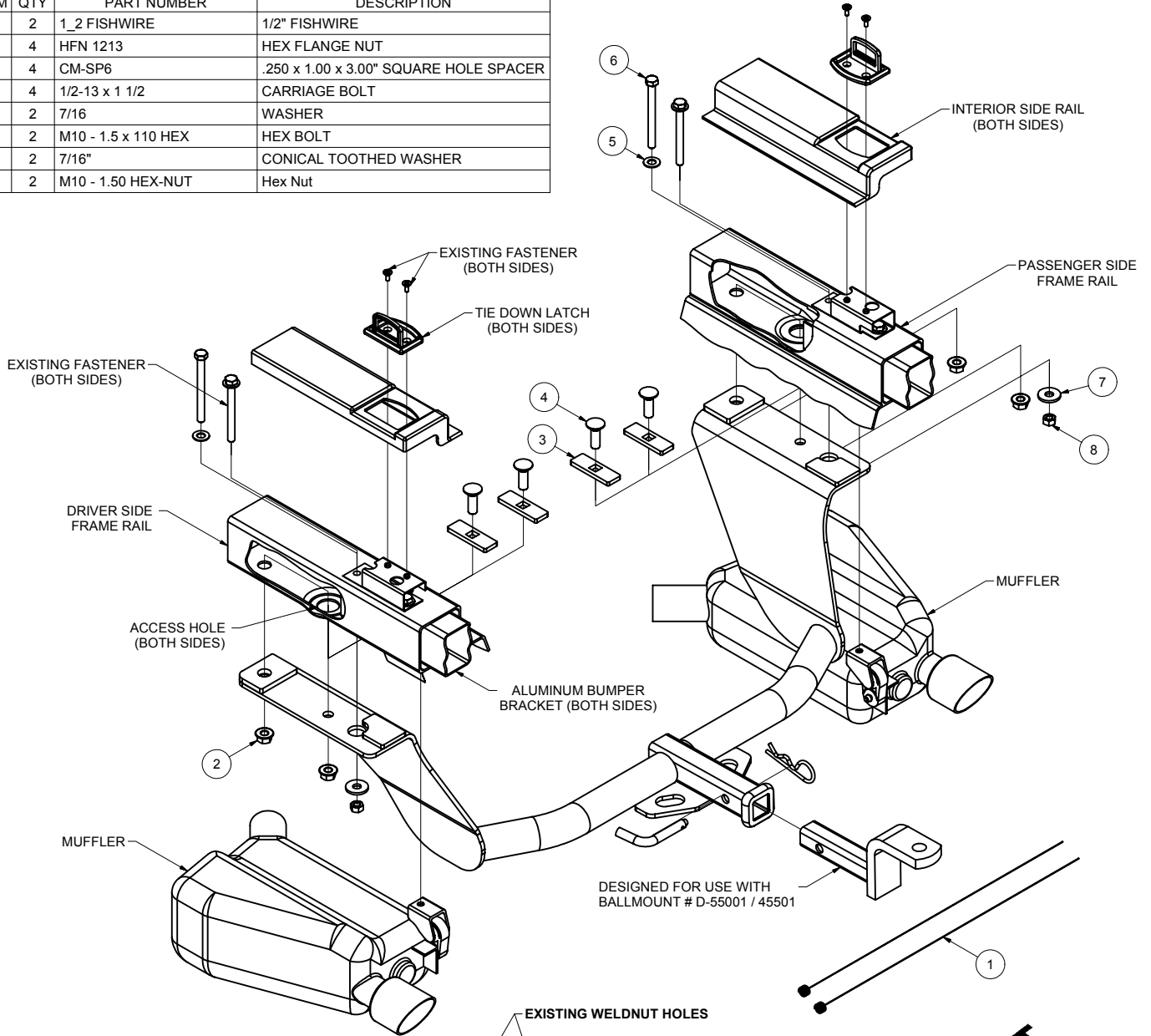

HEAT SHIELD TRIM DETAIL

FRONT
↑
REAR

HITCH WEIGHT: 35 LBS.
INSTALL TIME
 PROFESSIONAL: 45 MINUTES
 NOVICE (DIY): 90 MINUTES
INSTALL NOTES:
 - NO DRILLING REQUIRED
 - LOWER EXHAUST
 - HEAT SHIELD TRIMMING REQUIRED

PERIODICALLY CHECK THIS RECEIVER HITCH TO ENSURE THAT ALL FASTENERS ARE TIGHT AND THAT ALL STRUCTURAL COMPONENTS ARE SOUND.

Curt Manufacturing Inc., warrants this product to be free of defects in material and/or workmanship at the time of retail purchase by the original purchaser. If the product is found to be defective, Curt Manufacturing Inc., may repair or replace the product, at their option, when the product is returned, prepaid, with proof of purchase. Alteration to, misuse of, or improper installation of this product voids the warranty. Curt Manufacturing Inc.'s liability is limited to repair or replacement of products found to be defective, and specifically excludes liability for incidental or consequential loss or damage.

8/26/2009

GROSS LOAD CAPACITY WHEN USED AS A WEIGHT CARRYING HITCH: 2,000 LBS. TRAILER WEIGHT & 200 LBS. TONGUE WEIGHT.

*****DO NOT EXCEED VEHICLE MANUFACTURER'S RECOMMENDED TOWING CAPACITY.*****

WARNING: ALL NON-TRAILER LOADS APPLIED TO THIS PRODUCT MUST BE SUPPORTED BY AUXILIARY STABILIZING STRAPS.

**** FAILURE TO PROPERLY SUPPORT NON-TRAILER LOADS WILL VOID PRODUCT WARRANTY****

HAVING INSTALLATION QUESTIONS? CALL TECHNICAL SUPPORT AT 1-800-798-0813

TOOLS REQUIRED

| |
|-------------------|
| RATCHET |
| RATCHET EXTENSION |
| 10mm SOCKET |
| 13mm SOCKET |
| 16mm SOCKET |
| T-30 TORX |
| CENTER PUNCH |
| TORQUE WRENCH |

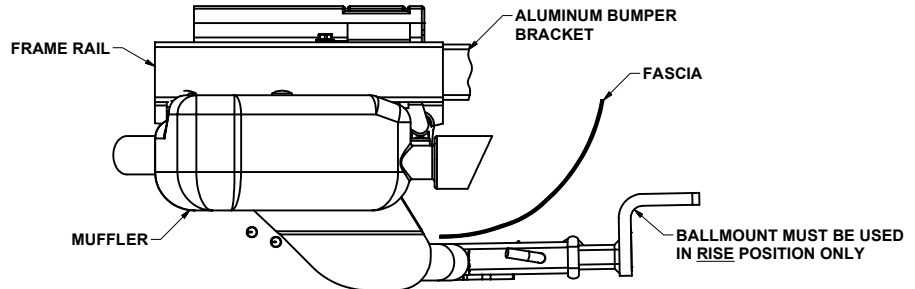
**HITCH SHOWN IN PROPER POSITION****RUBBER ISOLATOR REMOVAL DIAGRAM**

This technique can be used if and Exhaust Hanger Removal Pliers is not available.

Using a 5/8" open end wrench, slide the wrench up to the rubber isolator, cradling the hanger rod as shown. Next place the flat edge of a pry bar between the wrench and the hanger stop or hanger rod. Then simply rotate the pry bar toward the wrench to remove the rubber isolator.

Note: Using a spray lubricant or soapy water on the hanger rod and the rubber isolator helps removal.

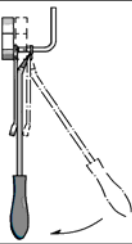
**FISHWIRE TECHNIQUE**

INSERT COILED END OF FISHWIRE TOOL THROUGH HITCH MOUNTING HOLE IN VEHICLE FRAME RAIL AND OUT THE ACCESS HOLE. PASS COILED END OF FISHWIRE THROUGH SPACER AND THREAD BOLT INTO COIL. KINK WIRE TO KEEP SPACER SEPARATE FROM BOLT AS SHOWN. PULL FISHWIRE, SPACER, AND BOLT THROUGH FRAME AND OUT MOUNTING HOLE. USE FISHWIRE TO GUIDE HITCH DURING MOUNTING AND PREVENT LOSS OF BOLT / SPACER INSIDE FRAME RAIL.

NOTE: SOME VEHICLES MAY FISHWIRE THROUGH END OF FRAME

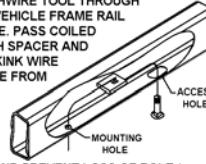
**REVERSE PULL FISHWIRE TECHNIQUE**

ATTACH FISHWIRE TO CARRIAGE BOLT AND SLIDE SPACER ONTO FISHWIRE. PUSH THE BOLT THRU THE HOLE FOLLOWED BY THE SPACER (AS SHOWN). PULL BOLT BACK INTO POSITION, PROTRUDING FROM THE FRAME.

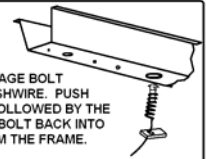
**INSTALLATION STEPS**

1. Removing fasteners from the exhaust brackets to lower exhaust, support as needed to prevent damage.
2. Raise hitch into position. Using a center punch, punch through the center hole of the hitch and into the heat shield.
3. Lower hitch and cut out the area of the heat shield covering the access hole. **See heat shield trim detail.**
4. Fishwire 1/2-13 X 1 1/2" carriage bolt and SP6 spacer through the access hole and out the forward most hole in frame, both sides. (SEE FISHWIRE TECHNIQUES)
5. Reverse fishwire 1/2-13 X 1 1/2" carriage bolt and SP6 spacer through the access hole, both sides. (SEE REVERSE FISHWIRE TECHNIQUES)
6. Open rear hatch and remove middle lid covering the spare tire.
7. Remove the rear most tie down latches from both side rails.
8. Remove the side rails.
9. Remove the forward most bumper bracket fastener and return to owner.
10. Replace bumper bracket fastener with M10-1.5 X 110 hex bolt and 7/16" flat washer, both sides.
11. Torque M10-1.5 X 110 hex bolts to 35 ft-lbs.
12. Reinstall all trunk components and close hatch.
13. Raise hitch into position, as shown.
14. Secure the (4) forward most bolts with 1/2" flange nuts.
15. Secure the rear most bolts with 7/16" conical toothed washer and M10 hex nut.
16. Torque all M10 hardware to 35 ft-lbs. Torque all 1/2" hardware to 75 ft-lbs.
17. Reinstall exhaust.

PERIODICALLY CHECK THIS RECEIVER HITCH TO ENSURE THAT ALL FASTENERS ARE TIGHT AND THAT ALL STRUCTURAL COMPONENTS ARE SOUND.