

13534

TOYOTA HIGHLANDER SPORT 3.5L V6 4X4

4/13/2009

GROSS LOAD CAPACITY WHEN USED AS A WEIGHT CARRYING HITCH: 5,000 LBS. TRAILER WEIGHT & 500 LBS. TONGUE WEIGHT.
 GROSS LOAD CAPACITY WHEN USED AS A WEIGHT DISTRIBUTION HITCH: 5,000 LBS. TRAILER WEIGHT & 500 LBS. TONGUE WEIGHT
*****DO NOT EXCEED VEHICLE MANUFACTURER'S RECOMMENDED TOWING CAPACITY.*****

Parts List			
ITEM	QTY	PART NUMBER	DESCRIPTION
1	7	M10 - 1.25 x 30	HEX BOLT
2	7	3/8"	CONICAL TOOTHED WASHER

SUGGESTED TOOLS

14MM 3/8" DRIVE SOCKET

17MM 3/8" DRIVE SOCKET

3/8" DRIVE RATCHET

5" LONG 3/8" DRIVE EXTENSION

FLAT DRIVE SCREW DRIVER

PHILLIPS DRIVE SCREW DRIVER

3/8" DRIVE TORQUE WRENCH

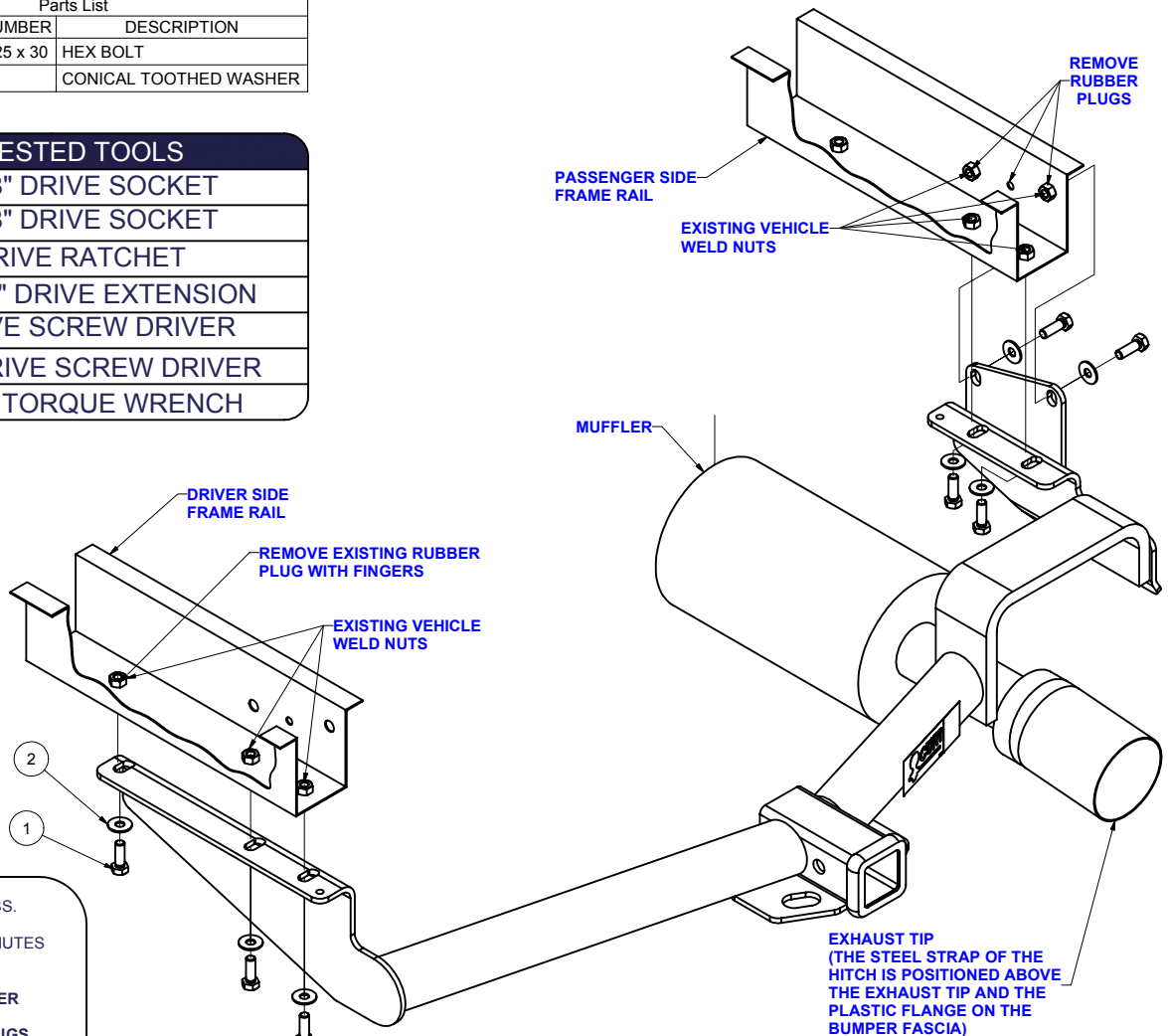

HITCH WEIGHT: 39 LBS.

INSTALL TIME: 45 MINUTES

INSTALL NOTES:

- REMOVE PLASTIC UNDER BODY PANELS
- REMOVE WELDNUT PLUGS
- NO DRILLING REQUIRED

INSTALLATION STEPS

- 1) Using the flat head screw driver, remove all push fasteners in underbody panels. Use a phillips drive screw driver to remove remaining screws. Use the 14mm socket and ratchet to remove the bolt holding the passenger side panel. The passenger side will be re-installed later, the driver side panel will not and can be returned to owner.
- 2) Using the 14mm socket, remove both tow loops and return to owner. Remove 4 rubber plugs (3 on passenger side and 1 on driver side).
- 3) Carefully raise hitch over exhaust towards muffler and pull back to bumper over the plastic flange on the bumper. Position the hitch so the holes line up with existing holes in the frame rail.
- 4) Install supplied 10M -1.25 x 30 hex head bolts and 3/8" conical tooth washers as shown above.
- 5) Using a torque wrench, torque all 10M - 1.25 bolts to 37 lb-ft.
- 6) Re-install passenger side under body panel onto vehicle using hardware removed in step 1.

PERIODICALLY CHECK THIS RECEIVER HITCH TO ENSURE THAT ALL FASTENERS ARE TIGHT AND THAT ALL STRUCTURAL COMPONENTS ARE SOUND.

Curt Manufacturing Inc., warrants this product to be free of defects in material and/or workmanship at the time of retail purchase by the original purchaser. If the product is found to be defective, Curt Manufacturing Inc., may repair or replace the product, at their option, when the product is returned, prepaid, with proof of purchase. Alteration to, misuse of, or improper installation of this product voids the warranty. Curt Manufacturing Inc.'s liability is limited to repair or replacement of products found to be defective, and specifically excludes liability for incidental or consequential loss or damage.